

Product Description

The RWF111 is an integrated RF Front End Module designed for 802.11 b/g WLAN applications at 2.4-2.5 GHz. The device consists of an integrated Power Amplifier, LNA and Switch. This module supports a data rate of 54 Mbps and is capable of delivering linear power at 16 dBm for 802.11g and 19dBm for 802.11b with a very low current.

It can deliver a max. output power of 23dBm @ 0dBm Pin. The FEM is fully matched internally to a 50ohm input/output impedance.

Features

- Frequency range of 2.4 GHz to 2.5 GHz
- Integrated PA/LNA/SPDT switch
- 802.11b/g Operation
- 802.11g/54 Mbps- 4% EVM at Pout=16dBm with a very low current
- Pout = 23 dBm @ Pin 0dBm, Vcc 3.6V
- Integrated Power Detector
- Operation from 2.9 V to 4.5V
- Package: 3.0 x 3.0 x 0.75mm³ QFN16 Package

Application

- 802.11b DSSS WLAN
- 802.11g OFDM WLAN
- 2.4GHz Cordless Phones
- 2.4GHz ISM Radios
- 2.4GHz Digital Home Wireless Audio/Video
- IEEE 802.15.4 and Zigbee Systems
- Wireless Audio Systems
- Wireless Consumer Systems
- Wireless Sensor Networks
- All 2.4GHz ISM Band Systems
- Wireless Industrial Systems

Advantages

- Integrated Single Chip Solution
- Integrated Power Detector
- Very Low Current Consumption
- Low Noise Figure
- Miniature Package

Functional Block Diagram

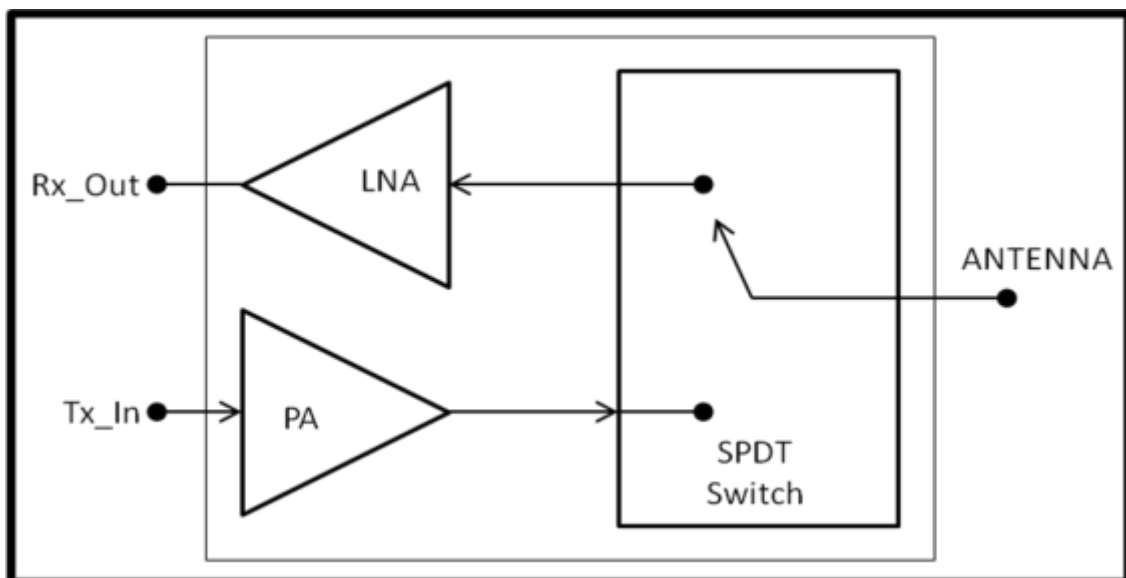

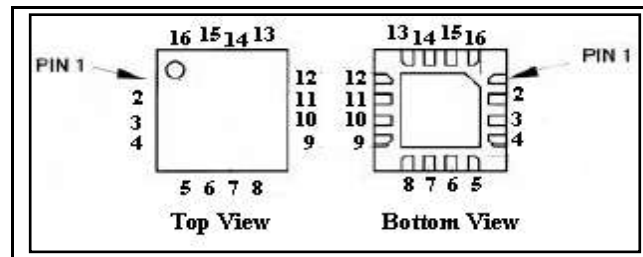
Outline Drawing

Pin Configuration

Pin No.	Name	Description
1	V_CntI2 2.9 – 4.5 V / 0.0 – 0.2 V	Enable/ Disable the switch in receive path with logic high 2.9V and logic low 0 – 0.2V
2	LNA_EN 2.2 – 3.0 / 0 V	Low Noise Amplifier Enable pin. A digital control signal with logic high (power up) and logic low (power down) is used to turn the device on and off.
3	LNA_Reg 2.85 – 3.3 V	Supply voltage for bias circuits of Low Noise Amplifier
4	LNA_Vcc 3.6 V	Drain supply voltage for Low Noise Amplifier having 3.6V typical value
5	Rx_Out	RF output power from Low Noise Amplifier
6	GND	RF Ground
7	Tx_In	RF input power for power amplifier
8	GND	RF Ground
9	PA_EN 2.2 – 3.0 / 0 V	Power Amplifier Enable pin. A digital control signal with logic high (power up) and logic low (power down) is used to turn the device on and off.
10	PA_Reg 2.85 – 3.3 V	Supply voltage for bias circuits of Power Amplifier
11	PA_Vcc 3.6 V	Drain supply voltage for Power Amplifier having 3.6V typical value
12	GND	RF Ground
13	V_PD	DC voltage corresponding to the RF output power from Power Amplifier
14	Vt 0.2 V	Control Voltage for switch irrespective of Tx/Rx path on
15	V_CntI1 2.9 – 4.5 V / 0.0 – 0.2 V	Enable/ Disable the switch in transmit path with logic high 2.9V and logic low 0 – 0.2V
16	ANTENNA	RF Output/Input for transmit and receive path respectively

Specifications

Absolute Maximum Ratings

Name	Description
PA_Vcc, LNA_Vcc	+5 V
VCnt1, VCnt2	+5 V
RF Input Power	+5 dBm
Operating Temperature Range	-40 to +85° C
Storage Temperature Range	-40 to +150° C

DC Electrical Characteristics

Conditions: PA_Vcc = LNA_Vcc = 3.6V, PA_Reg = LNA_Reg = 2.85V, V_Cnt1 = V_Cnt2 = 2.9V, PA_EN = LNA_EN = 2.2V, Vt = 0.2V, TA = 25°C, fc = 2.45GHz, using RF Arrays Evaluation Board.

Name	Descriptions	Unit	Typical
ISTBT	Leakage Current when PA_EN=0V, V_Cnt1=0V	μA	20
ISTBR	Leakage Current when LNA_EN = 0V, VCnt2 = 0V	μA	0.1

Transmit Path Electrical Characteristics at 25° C

Name	Conditions	Unit	Min.	Typ.	Max.
Frequency		GHz	2.4	2.45	2.5
Small Signal Gain		dB	27	28	
P1dB		dBm	21.5	22	
EVM	Pout @ 16 dBm OFDM/54 Mbps	%		4	
	Pout @ 19 dBm CCK/11 Mbps	%		1.2	
Quiescent Current	Vcc @ 3.6 V	mA	47	57	
Current at 3.6 V under modulating signal	Pout @ 16 dBm	mA		97	
	Pout @ 19 dBm	mA		125	
Output Power	Vcc @ 3.6 V, Pin @ 0 dBm	dBm	22.5	23	
Peak Current	Pout @ 23 dBm	mA		205	
Input Return Loss		dB	11		
Output Return Loss		dB	7		
Isolation:					
	Tx-Rx	dB	22		
	Rx-Antenna	dB	22		
2nd Harmonic	Pout @ 16 dBm	dBm	-14		
3rd Harmonic	Pout @ 16 dBm	dBm	-27		
IM3	Pout @ 16 dBm, 1MHz, 5 MHz	dBc	-35		

Receiver Path Electrical Characteristics at 25° C

Name	Conditions	Unit	Min.	Typ.	Max.
Frequency		GHz	2.4	2.45	2.5
Small Signal Gain		dB	13	14	
Noise Figure		dB		2.2	
Quiescent Current	Vcc @ 3.6 V	mA	6	9	
IIP3		dBm		3	
Input Return Loss		dB	9		
Output Return Loss		dB	7		
Tx-Antenna Isolation		dB	22		

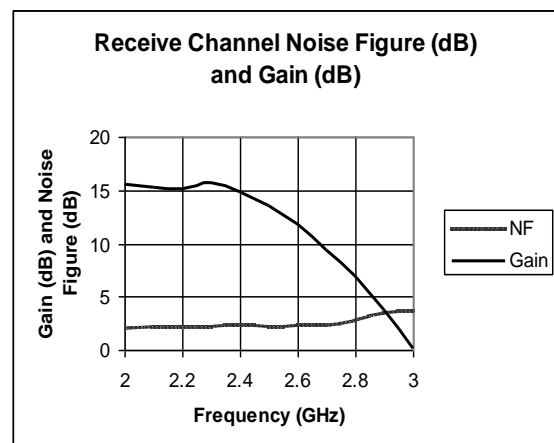
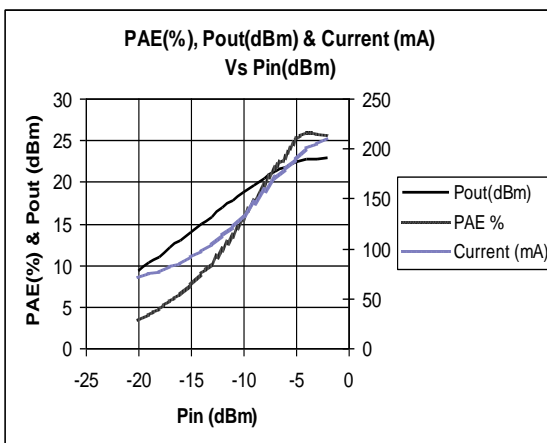
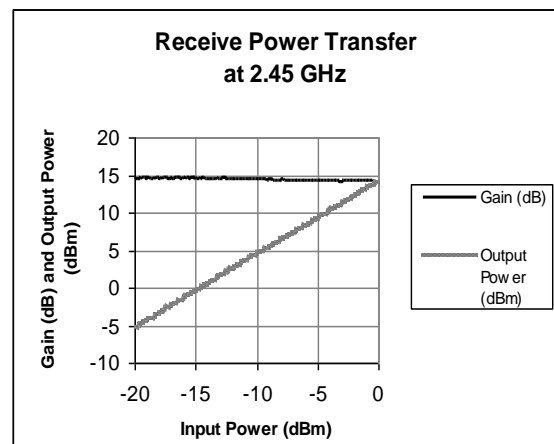
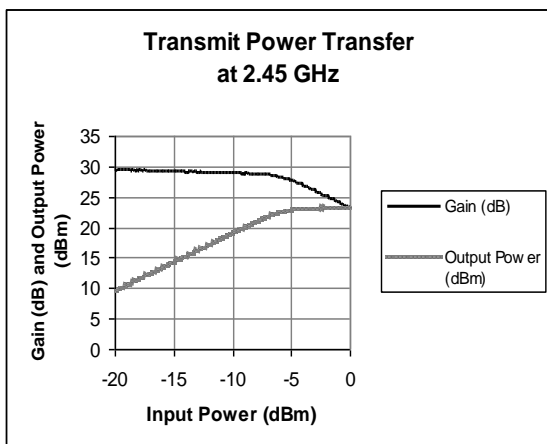
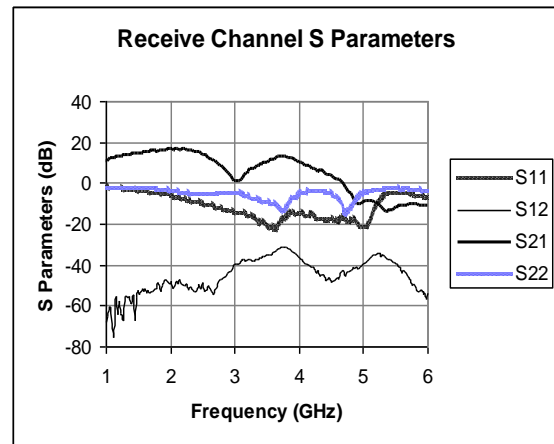
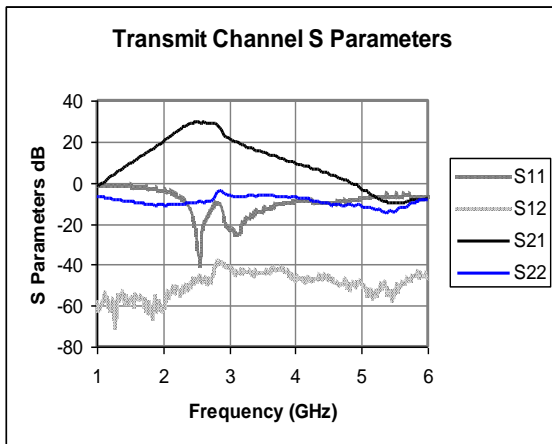
Measured Data

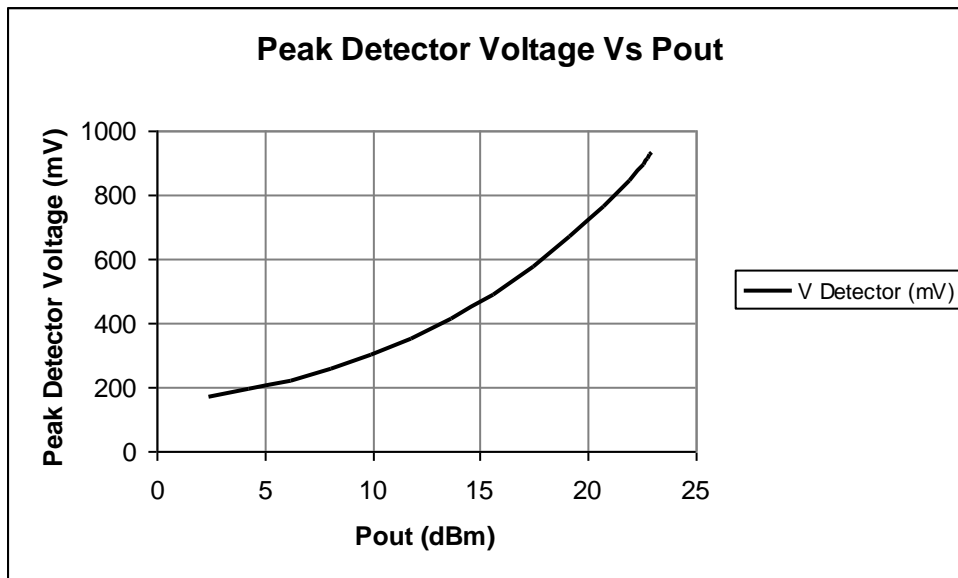

EVM for 802.11g (54 Mbps)
Pout = 16 dBm, Freq = 2442 MHz

EVM for 802.11b (11 Mbps)
Pout = 19 dBm, Freq = 2442 MHz

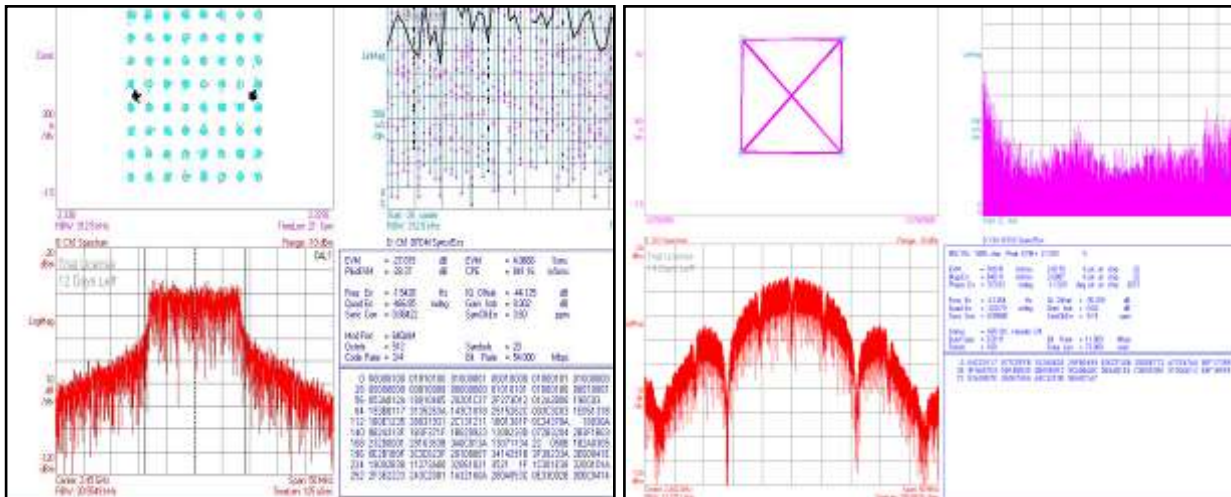

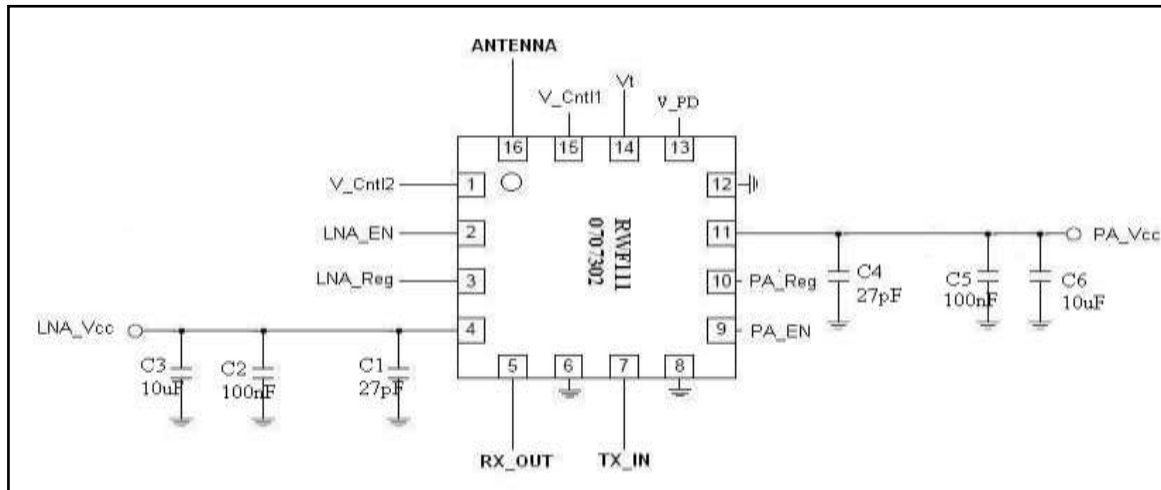
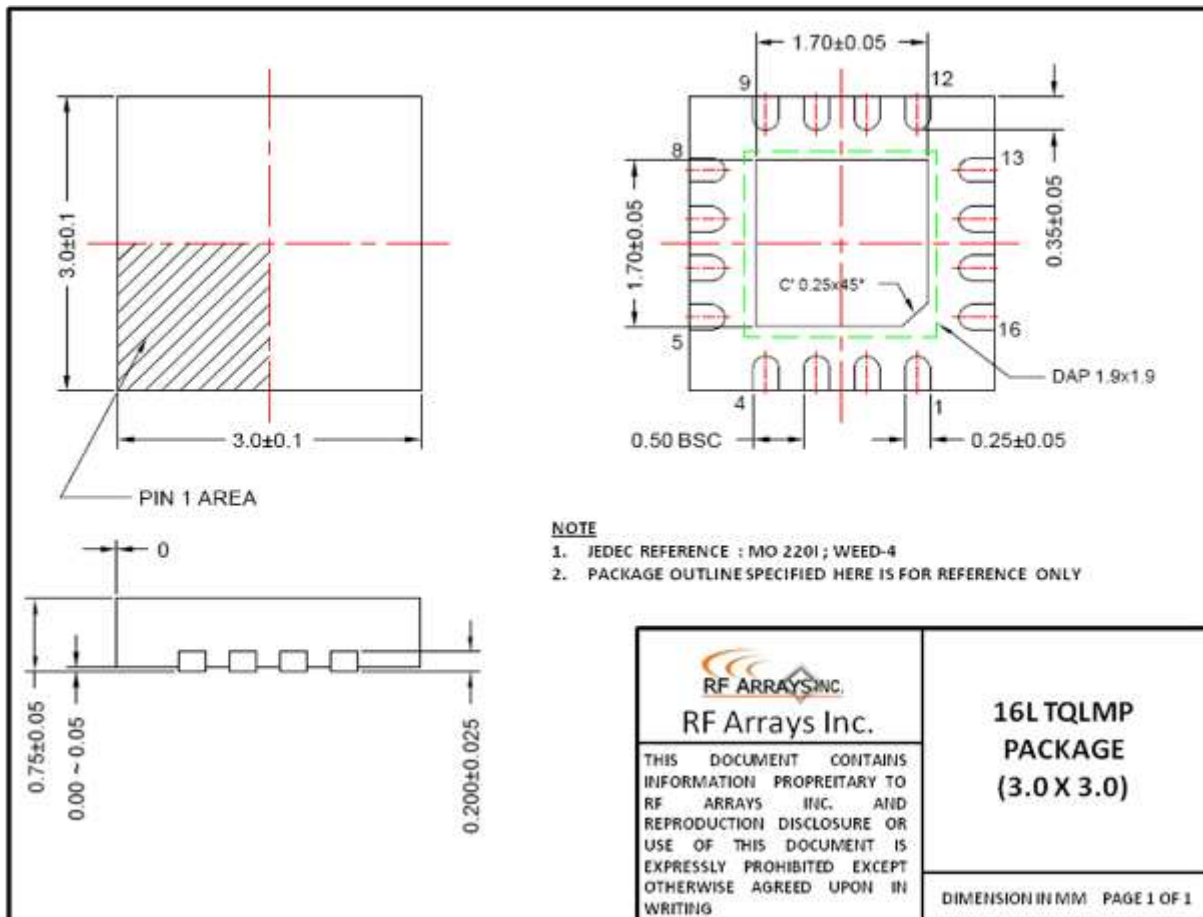
PIN Configuration

Package Drawings

<http://www.rfarrays.com>

Customer Service Locations

USA

RF Arrays Inc.
PO Box 14948.
Fremont California 94539, USA

Email: info@rfarrays.com,
sales@rfarrays.com

INDIA

RF Arrays Systems Pvt. Ltd.
106, Infotech Towers
South Ambazari Road
Nagpur Maharashtra

Ph: 91-712-2242459
Fax: 91-712-2249429
Email: info@rfarrays.com,
sales@rfarrays.com

Product Preview

The document contains information from the product concept specification. RF Arrays Inc. reserves the right to change information at any time without notification.

Preliminary Information

The document contains information from the design target specification. RF Arrays Inc. reserves the right to change information at any time without notification.

Production testing may not include testing of all parameters.

Information furnished is believed to be accurate and reliable and is provided on an "as is" basis. RF Arrays Inc. assumes no responsibility or liability for the direct or indirect consequences of use of such information nor for any infringement of patents or other rights of third parties, which may result from its use. No license or indemnity is granted by implication or otherwise under any patent or other intellectual property rights of RF Arrays Inc. or third parties. Specifications mentioned in this publication are subject to change without notice. This publication supersedes and replaces all information previously supplied. RF Arrays Inc. products are NOT authorized for use in implantation or life support applications or systems without express written approval from RF Arrays Inc.

Copyright 2007 RF Arrays, Inc.
All Rights Reserved