

RF Arrays High Power Module with Jennic JN5139

RIM511 High Power ZigBee Wireless Module

RF Arrays, with its expertise in ZigBee solutions provides complete hardware & software solutions for 802.15.4 ZigBee applications. RIM511, RF Arrays high power ZigBee module, operates in a license free 2.4GHz ISM band and provides stable and continuous interaction in a wireless star/mesh network for a secured data management.

RIM511 is a low cost, IEEE 802.15.4 compliant wireless module based on RF ARRAYS, Front End Module RIF211 and Jennic, wireless microcontroller. Jennic, JN5139 comprises of 32-bit RISC core micro controller, a fully compliant 2.4 GHz IEEE 802.15.4 transceiver, 192kB of ROM and 96kB of RAM. It is integrated with indigenously developed RF Arrays FEM RIF211 that incorporates power amplifier, low noise amplifier and switch as a integrated solution on a single chip. RIF211 provides high power out of 20 dBm in transmit mode with a very high sensitivity in receiver chain enabling this module to work for long range & high data rates. The transmitting range goes better than 1 km. RF Arrays ZigBee solution provides a versatile & low cost solution for wireless sensor networking applications.

This high level of integration is done by RF ARRAYS and helps to reduce the overall system cost by providing a small foot print, low component count reference design. In particular, this module enables integration of point-to-point, linear and mesh network stack protocols, and allows support of router and controller functions without the need for additional external memory. The RF Arrays ZigBee module uses hardware MAC and highly secure AES encryption accelerators for low power consumption and minimum processor overhead. Integrated sleep oscillator and power saving facilities are provided, giving low system power consumption.



40mm x 18mm

RF Arrays High Power ZigBee Module

Features: RIM511 Module

- ✓ 2.4GHz IEEE802.15.4 compliant
- ✓ 128-bit AES security processor
- ✓ MAC accelerator with packet formatting, CRCs, address check, auto-acks, timers
- ✓ Integrated power management and sleep oscillator for low power
- ✓ On-chip power regulation for 3.2V to 3.6V battery operation
- ✓ Deep sleep current 8μA
- ✓ Sleep current with active sleep timer 9.3μA
- ✓ Needs minimum of external components
- ✓ Rx current 54mA
- ✓ Tx current 155mA
- ✓ Receiver sensitivity -103dBm
- ✓ Transmit power +18dBm
- ✓ 32-bit RISC processor sustains 32MIPs with low power
- ✓ 192KB ROM stores system code, including protocol stack
- ✓ 96KB RAM stores system data and optionally boot loaded program code
- ✓ 48-byte OTP eFuse, stores MAC ID on-chip, offers AES based code encryption feature
- ✓ 4-input 12-bit ADC, 2 11-bit DACs, 2 comparators
- ✓ 2 Application timer/counters, 3 system timers
- ✓ 2 UARTs (one for debug)
- ✓ SPI port with 5 selects
- ✓ 2-wire serial interface
- ✓ Up to 21 GPIO
- ✓ Industrial temperature range (-40°C to +85°C)



www.rfarrays.com

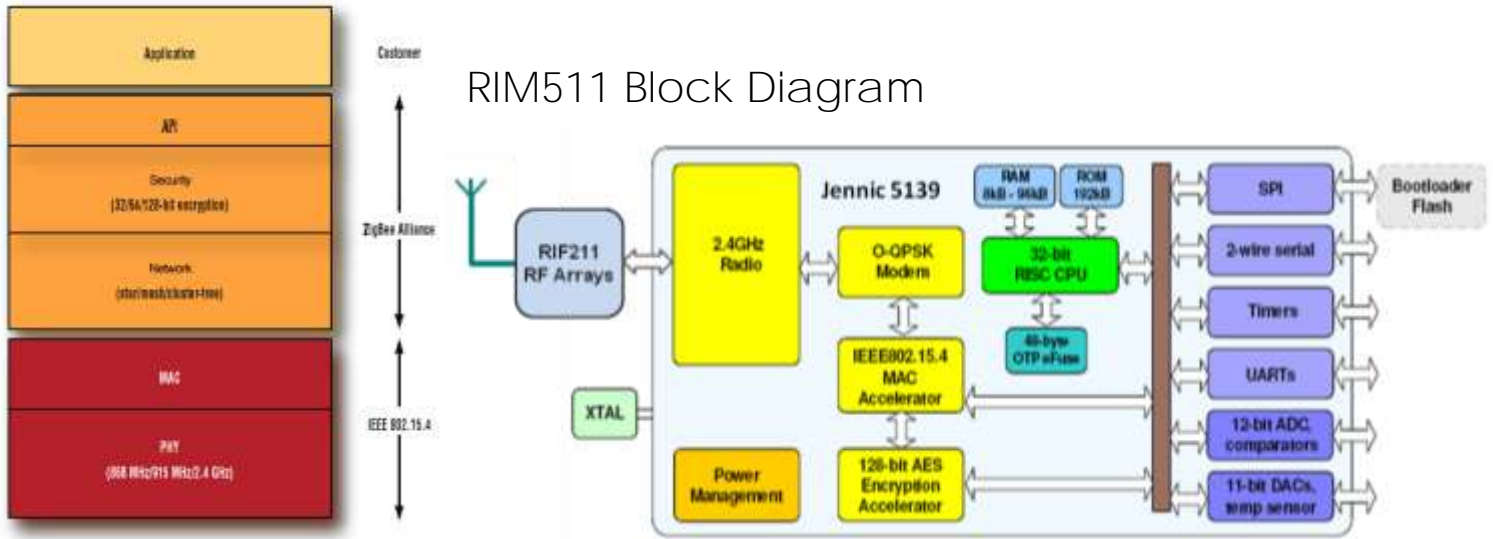

The network layers in this ZigBee stack use the well-known Open Systems Interconnection (OSI) Model. The IEEE 802.15.4 standard specifies the PHY and MAC layer. The ZigBee Alliance defines the network and security layers and the application programming interface (API). RF Arrays application programs comprise the upper layers.

DESCRIPTION

RF Arrays provides software support on API to allow higher-level protocols and applications to use the MAC control and data services.

- ≈ It Provides a small footprint, low component count reference design. The hardware can be incorporated into a system by simply mounting the module on a motherboard. The footprint allows access to all the analog and digital IO provided by the processor that requires only power (if not battery operated) and reset signals to be fed to the module.
- ≈ RIM511 provides a complete solution for wireless sensor network applications. A basic packet sniffer and network test application is already embedded. Depending on the requirement, these RF Arrays ZigBee modules can be arranged in different topologies like STAR, TREE, LINEAR and MESH.

SPECIFICATIONS

ZigBee Device Specifications:

1. RFD (Reduced Function Device)
 - ≈ Stack: IEEE 802.15.4
 - ≈ Low Memory & Software Overhead
 - ≈ Prominently a Sleepy Device
 - ≈ Low Duty Cycle Operations
2. Full Function Device (Coordinator/Router)
 - ≈ Stack: IEEE 802.15.4 & ZigBee Mesh Stack
 - ≈ More Memory & Software Overhead
 - ≈ Prominently an Active Device (Always On)
 - ≈ Long Range Capability (High Power Module with transmitting range better than 1km)

ZIGBEE HIGHLIGHTS

- ≈ Standards-based solution without the drawbacks of proprietary systems.
- ≈ Worldwide interoperability in 2.4 GHz band..
- ≈ Reliable and easy-to-deploy network supporting large number of nodes.
- ≈ Secure communication between nodes.
- ≈ Nodes may be added or removed without network interruptions.
- ≈ Real time updates register on the end devices through commands from the gateway.
- ≈ Optimization of available bandwidth and minimization of network activity.
- ≈ Re-establishment of the entire network in case of poor network health.
- ≈ The above features impart a unique combination of flexibility and robustness to the solution.

ZIGBEE CAPABILITIES

- ≈ Full ZigBee device type support: ZigBee Coordinator (ZC), ZigBee Router/Gateway (ZR), and ZigBee End Device (ZED)
- ≈ Fully integrated MAC and NWK layers provide the smallest FLASH and RAM footprints in the industry.
- ≈ Support for portable end devices, where a device may be used in different parts of a network. For example, a remote control that may be moved from one part of the network to another.
- ≈ Full ZigBee APS support, to allow easy support of ZigBee specified public application profiles.

USA

RF Arrays Inc.
 1722 NW Raleigh
 St. Suite 404. Portland
 Oregon 97209, USA
 Contact: Rupert Prince
 ☎ 503-287-5238
 ✉ rprince@rfarrays.com

INDIA

RF Arrays Systems Pvt. Ltd.
 106, Infotech Towers
 South Ambazari Road
 Nagpur Maharashtra
 ☎ 91-712-2242459
 ☎ 91-712-2249429
 ✉ info@rfarrays.com

Asia/Pacific

RF Arrays Systems Pvt. Ltd.
 3F, Hanwon Bldg, 6-1 Sunae-
 Dong, Bundung-Gu, Seongnam
 City, Gyunggi-Do, Korea
 Contact : Kyungsoo Jun
 ☎ 82-10-9467-1967
 ✉ jun@rfarrays.com