

Product Description

The RBS641 is a high performance Gallium Arsenide Double pole double throw broad band RF switch. It is suitable for use in broadband communications and instrumentation applications. A short circuit reflective termination is presented at the isolated outputs of the switch. The switch is controlled by the application of complimentary 0V/-5V or 0/-8V signals to the control lines in accordance with the truth table below.

Features

- Broadband performance
- Low Insertion Loss; 0.6 dB typ at 2 GHz
- Ultra low DC power consumption

Functional Block Diagram

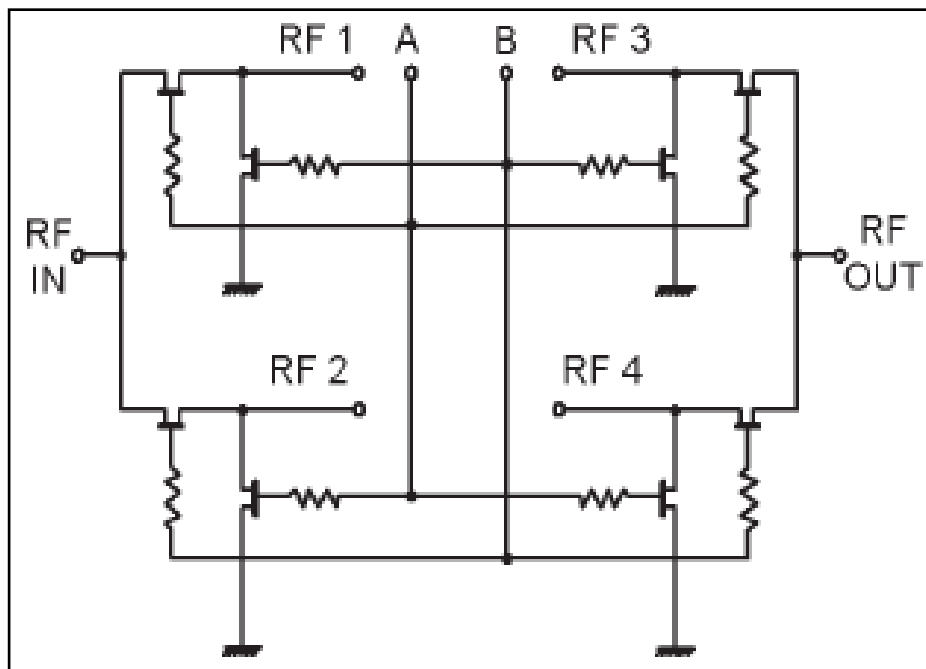

Specifications

Absolute Maximum Ratings

Name	Description
Max Control Voltage	-8 V
RF I/P Power	+30 dBm
Operating Temperature Range	-40 to +85° C

Electrical Performance

Typical performance at 25°C

Ambient temperature = 25±3°C, Zo = 50 Ω, Control voltage = 0V/-5V unless otherwise stated

Parameter	Condition	Min.	Typ.	Max.	Units
Insertion Loss ¹	DC – 3 GHz	-	0.57	0.6	dB
	3 – 6 GHz	-	0.85	0.9	dB
Isolation ¹	DC – 3 GHz	68	70	-	dB
	3 – 6 GHz	63	64	-	dB
Input Return Loss ²	DC – 3 GHz	25	29	-	dB
	3 – 6 GHz	16	25	-	dB
Output Return Loss ²	DC – 3 GHz	25.6	28	-	dB
	3 – 6 GHz	18	25	-	dB
P1dB power compression point ³	0/-5 V control; 50 MHz	-	19.5	-	dBm
	0/-5 V control; 0.5 - 4 GHz	-	25.5	-	dBm
	0/-8 V control; 50 MHz	-	21.5	-	dBm
	0/-8 V control; 0.5 - 4GHz	-	28	-	dBm
Switching Speed	50% control to 10%/90% RF	-	2.2	-	ns

Notes

1. Insertion loss and Isolation measured between RF Input and any output.
2. Return Loss measured in low loss switch state.
3. Input power at which insertion loss compresses by 1dB.

Preliminary Data

Insertion Loss

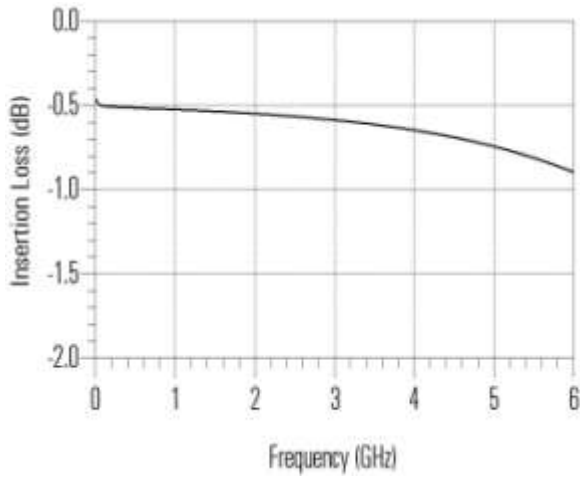

Isolation

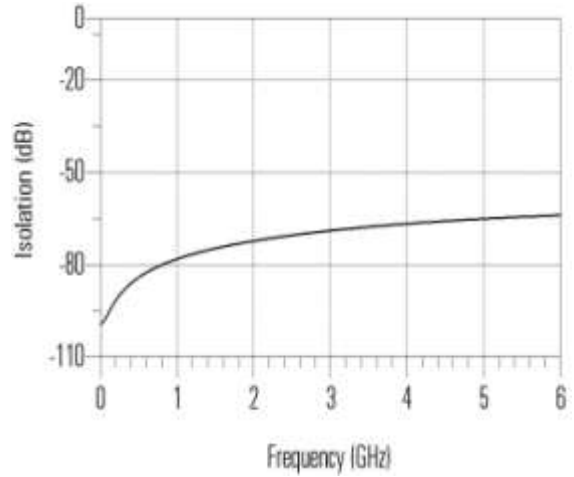

Input Return Loss

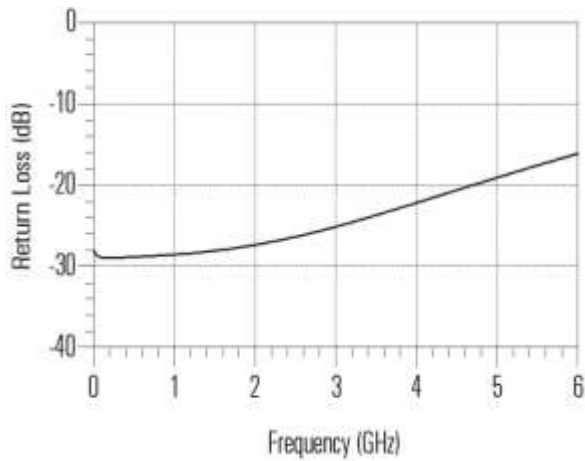

Output Return Loss

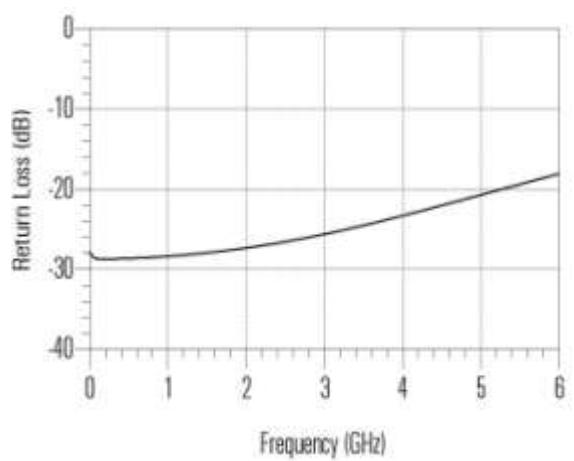

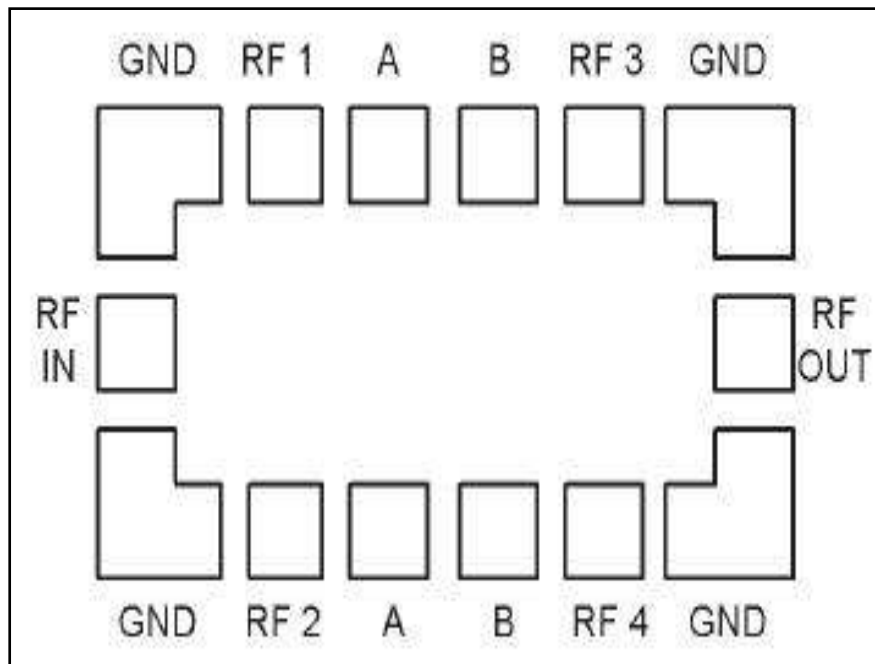
Chip Outline Diagram

Die size: 1.2 X 1.5 mm
 Minimum Bond pad size: 120 μ m x 120 μ m
 Die thickness: 200 μ m

Switching Truth Table

A	B	RF IN-RF1	RF IN-RF2
		RF3-RF OUT	RF4-RF OUT
0 V	-5 V	Low Loss	Isolated
-5 V	0 V	Isolated	Low Loss

<http://www.rfarrays.com>

Customer Service Locations

USA

RF Arrays Inc.

1722 NW Raleigh St. Suite 404.
Portland Oregon 97209, USA
Contact Person: Rupert Prince

Sales: 503-287-5238

Email: rprince@rfarrays.com

INDIA

RF Arrays Systems Pvt. Ltd.

106, Infotech Towers
South Ambazari Road
Nagpur Maharashtra

Ph: 91-712-2242459

Fax: 91-712-2249429

Email: sales@rfarrays.com

Asia/Pacific

RF Arrays Systems Pvt. Ltd.

3F, Hanwon Bldg, 6-1 Sunae-
Dong, Bundung-Gu, Seongnam
City, Gyunggi-Do, Korea
Contact Person: Kyungsoo Jun

HF: 82-10-9467-1967

Email: jun@rfarrays.com

Product Preview

The document contains information from the product concept specification. RF Arrays Inc. reserves the right to change information at any time without notification.

Preliminary Information

The document contains information from the design target specification. RF Arrays Inc. reserves the right to change information at any time without notification.

Production testing may not include testing of all parameters.

Information furnished is believed to be accurate and reliable and is provided on an “as is” basis. RF Arrays Inc. assumes no responsibility or liability for the direct or indirect consequences of use of such information nor for any infringement of patents or other rights of third parties, which may result from its use. No license or indemnity is granted by implication or otherwise under any patent or other intellectual property rights of RF Arrays Inc. or third parties. Specifications mentioned in this publication are subject to change without notice. This publication supersedes and replaces all information previously supplied. RF Arrays Inc. products are NOT authorized for use in implantation or life support applications or systems without express written approval from RF Arrays Inc.

Copyright 2007 RF Arrays, Inc.

All Rights Reserved