

RF Arrays High Power Module with Nordic nRF24L01 Transceiver

RIM541 High Power ISM Wireless Module

RF Arrays, with its expertise in RF & Wireless solutions provides complete hardware & software solutions for 2.4 GHz ISM band applications. RIM541, RF ARRAYS high power module operates in a license free 2.4GHz ISM band and provides stable and continuous interaction in a wireless 1:6 star network for a secured data management.

RIM541 is based on RF ARRAYS Front End Module RIF211 and Nordic Semiconductor nRF24L01, a low power 2.4 GHz transceiver with embedded baseband protocol engine (Enhanced ShockBurst™). It is integrated with indigenously developed RF Arrays FEM RIF211 that provides a versatile & low cost solution for wide range of wireless networking applications. RIF211 provides high power out of 20 dBm in transmit mode with a very high sensitivity in receiver chain enabling this module to work for long range & high data rates. The transmitting range goes better than 800meters.

This high level of integration is done by RF ARRAYS and It helps to reduce the overall system cost by providing a small foot print, low component count reference design. In particular, this module enables integration of point-to-point, 1:6 star network and allows data transmission at 2Mbps RF link. An MCU (micro-controller) and very few external passive components are needed to design a radio system with RIM541 for short range to medium range applications. RIM541 is configured and operated through a serial peripheral interface (SPI) and provide access to the register map. The register map contains all the configuration registers of nRF24L01 and accessibility in all operation modes of the module.

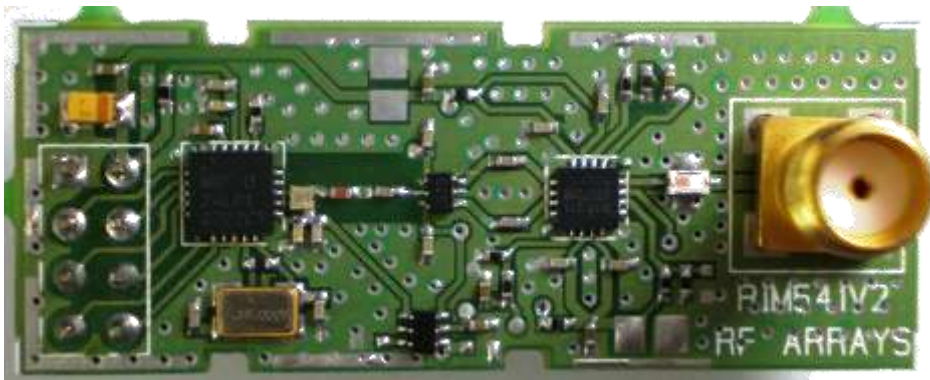

RF Arrays High Power ISM Module

44mm x 17mm

Features: RIM541 Module

- ✓ Worldwide 2.4GHz ISM band operation
- ✓ GFSK modulation
- ✓ Up to 2Mbps on air data rate
- ✓ 130mA TX at 17dBm output power
- ✓ Programmable output power: +2, +8, +14 or +17dBm
- ✓ Integrated filters for FCC & ETSI regulation
- ✓ 22mA RX at 2Mbps air data rate
- ✓ -85dBm sensitivity at 2Mbps
- ✓ -88dBm sensitivity at 1Mbps
- ✓ Programmable LNA gain
- ✓ On chip voltage regulator
- ✓ 3.2 to 3.6V supply range
- ✓ Enhanced Shock Burst™
- ✓ 1 to 32 bytes dynamic payload length
- ✓ Automatic packet handling
- ✓ Auto packet transaction handling
- ✓ 6 Data pipe multiceiver™
- ✓ Air compatible with nRF2401A, 02, E1 and E2
- ✓ 4-pin hardware SPI
- ✓ Max 8Mbps SPI operation
- ✓ 3 separate 32 bytes TX and RX FIFO
- ✓ 5V tolerant inputs
- ✓ Low cost BOM
- ✓ Industrial Temperature range (-40°C to +85°C)



www.rfarrays.com

RIM541 Block Diagram

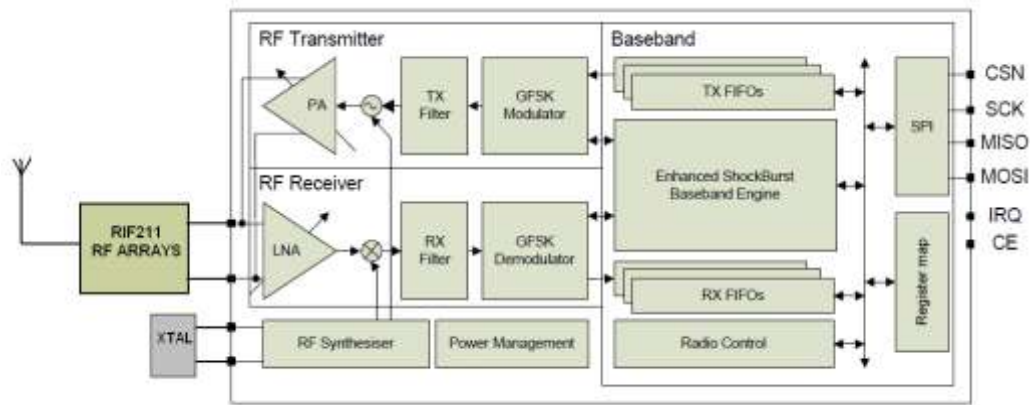

RIM541 module is based on nRF24L01. It inherits all the features of this transceiver and provides the long range capability with greater data reliability in adverse conditions with RIF211. This module can be operated with Enhanced Shock Burst™ which is a packet-based data link layer. It features automatic packet assembly and timing, automatic acknowledgment and retransmissions of packets. Enhanced Shock Burst™ enables the implementation of ultra low power, high performance communication with low cost host microcontrollers. The features enable significant improvements of power efficiency for bidirectional and unidirectional systems, without adding complexity on the host controller side.

DESCRIPTION

- ≈ RF Arrays provides full software support on API to allow higher-level protocols and applications to use the Enhanced Shock Burst™ and data services.
- ≈ It provides small footprint and low component count reference design. RF and supply decoupling issues are well taken care of in the module which allow this module to use in system easily with low cost host micro-controllers. The footprint allows access to serial peripheral interface (SPI), interrupt and power supply through 8 Pin connector.
- ≈ RIM541 provides a complete solution for wireless applications at 2.4 GHz. It uses GFSK modulation and has user configurable parameters like frequency channel, output power and air data rate.

SPECIFICATIONS

1. Operating frequency 2.4GHz – 2.484 GHz
2. Tx Output power +17 dBm
3. Tx Current: max 130mA
4. Rx sensitivity -88 dBm
5. Rx Current: max 22 mA
6. SPI operation: max 8 Mbps
7. 6 data pipe MultiCeiver™
8. Range 800m

APPLICATIONS

- ≈ Wireless PC Peripherals
- ≈ Mouse, keyboards and remotes
- ≈ 3-in-one desktop bundles
- ≈ Advanced Media center remote controls
- ≈ VoIP headsets
- ≈ Game controllers
- ≈ Sports watches and sensors
- ≈ RF remote controls for consumer electronics
- ≈ Home and commercial automation
- ≈ Ultra low power sensor networks
- ≈ Active RFID
- ≈ Asset tracking systems
- ≈ Toys

USA

RF Arrays Inc.
PO Box 14948,
Fremont California 94539, USA
✉ info@rfarrays.com,
sales@rfarrays.com

INDIA

RF Arrays Systems Pvt. Ltd.
106, Infotech Towers
South Ambazari Road
Nagpur Maharashtra
☎ 91-712-2242459
☎ 91-712-2249429
✉ info@rfarrays.com,
sales@rfarrays.com